

Reference Manual

INTEGRATED AMPLIFIERS SUPERNAIT 3 • NAIT XS 3 • NAIT 5si



Contents

<u>Section</u>	<u>Page</u>
Introduction	E1
1. Connections	E1
2. Mains Power	E1
3. General Installation	E2
4. SUPERNAIT 3	E3
5. Controls and Connections	E5
6. System Upgrade Connections	E6
7. Operation and Programmable Functions	E7
8. NAIT XS 3	E8
9. Controls and Connections	E10
10. System Upgrade Connections	E11
11. Operation and Programmable Functions	E12
12. NAIT 5si	E13
13. Controls and Connections	E14
14. Operation and Programmable Functions	E14
15. NARCOM 5 Remote Handset	E16
16. Diagram Icons	E17
17. Specifications	E18
18. Product Recycling	E19

Introduction

Naim Audio products are conceived with performance as the top priority. Careful installation will help ensure that their full potential is achieved. This manual covers all integrated amplifiers. It begins with some general installation notes. Product specific information begins in Section 4.

Note: Please read the Statutory Safety Warnings found at the end of this manual.

1. Connections

It is important for both safety and performance that the standard cables supplied are not modified.

1.1 Interconnect Cables

If options are available with your equipment and installation, DIN interconnect sockets should be used in preference to RCA Phono sockets. One end of each Naim interconnect cable is marked with a band to establish its correct orientation. The band denotes the end that connects to the signal source. Naim Hi-Line interconnect cable will provide the best results.

Interconnect plugs and sockets should be kept clean and free from corrosion. The easiest way to clean them is to switch off the equipment, pull the plugs out of their sockets, and push them back in again. Contact cleaners and “enhancers” should not be used as the film they deposit may degrade the sound.

1.2 Loudspeaker Cables

Loudspeaker cables are vitally important. They should each be at least 3.5 metres long and of equal length. The recommended maximum is normally 20 metres although longer cables may be viable with some Naim amplifiers.

Some Naim amplifiers are designed only to work with Naim loudspeaker cable and using alternatives may degrade the performance or even damage the amplifier. Other Naim amplifiers can be used with any high quality loudspeaker cable although we recommend that Naim loudspeaker cable is used. Naim loudspeaker cable is directional and should be oriented so that the printed arrow points towards the speakers. The Naim loudspeaker connectors supplied are designed to comply with European safety legislation and must be used.

Contact your local retailer or distributor for further advice on loudspeaker cables and connectors.

2. Mains Power

Use only the mains leads and plugs supplied or the Naim PowerLine mains cable.

Where fused plugs are used 13 amp fuses should be fitted. Fuses of a lower rating will fail after a period of use. Do not wire voltage dependent resistors or noise suppressors into mains plugs. They degrade the mains supply and the sound.

2.1 Mains Plug Wiring

In some territories a mains plug may need to be fitted to the supplied mains lead. As the colours of the wires in the mains lead may not correspond with the coloured markings identifying the terminals in the plug proceed as follows:

The wire coloured GREEN-AND-YELLOW must be connected to the terminal in the plug marked by the letter E or by the safety earth symbol or coloured GREEN or GREEN and YELLOW.

The wire coloured BLUE must be connected to the terminal in the plug marked with the letter N or coloured BLACK.

The wire coloured BROWN must be connected to the terminal in the plug marked with the letter L or coloured RED.

2.2 Equipment Fuses

Mains powered Naim Audio equipment is fitted with a mains fuse on the rear panel adjacent to the mains input socket. Replace it if necessary only with the spare fuse supplied or with an identical fuse. Repeated failure of the fuse points to a fault that should be investigated by your retailer or Naim itself.

2.3 Non-rewirable Mains Plugs

If a non-rewirable plug is cut from a mains lead (for whatever purpose) the plug **MUST** be disposed of in a way to render it totally useless. Considerable shock hazard exists if the cut-off plug is inserted into a mains outlet.

2.4 Mains Circuits and Cables

A hi-fi system usually shares a mains circuit with other household equipment some of which can cause distortion of the mains waveform. This distortion can in turn lead to mechanical hum from mains transformers. Some Naim transformers are large in size, making them relatively sensitive to such distortion, and it may be necessary to take account of transformer hum when siting your equipment.

Transformer hum is not transmitted through the speakers and has no effect on the performance of the system; however, a separate mains circuit may reduce it. Such a circuit (ideally with a 30 or 45 Amp rating) will also generally improve system performance. Advice on the installation of a separate mains circuit should be sought from a qualified electrician.

3. General Installation

Naim equipment is designed to offer the finest performance possible avoiding compromise wherever practical. This can lead to circumstances that may be unfamiliar. The notes that follow contain advice specifically related to Naim equipment as well as more general warnings about the use of domestic audio products. Please read them carefully.

3.1 Siting The Equipment

In order to reduce the risk of hum audible from the loudspeakers, power supplies and power amplifiers should be located a reasonable distance away from other equipment. The maximum separation distance for connected equipment is that allowed by the standard interconnect lead.

Some Naim equipment is extremely heavy. Check the weight of the equipment prior to lifting and if necessary use more than one person so that it can be moved safely. Ensure that your equipment rack or table can easily support the weight and is stable.

3.2 Switching On

Source components and power supplies should be switched on before the power amplifiers. Always switch amplifiers off and wait a minute before connecting or disconnecting any leads. Always use the power switch on the product rather than a mains outlet switch.

A “thump” may be heard from the loudspeakers as power amplifiers are switched on. This is normal, will not cause any loudspeaker damage and does not point to any fault or problem. A mild “pop” may also be heard shortly after equipment is switched off.

3.3 Running In

Naim equipment takes a considerable time to run in before it performs at its best. The duration varies, but under some conditions the sound may continue to improve for over a month. Better and more consistent performance will be achieved if the system is left switched on for long periods. It is worth remembering however that equipment left connected to the mains can be damaged by lightning.

3.4 Radio Interference

In some circumstances, depending on where you live and the earthing arrangements in your home, you may experience radio frequency interference. Controls on broadcasting in some territories allow very high levels of radio frequency radiation and both the choice and exact siting of equipment may be critical. Susceptibility to radio frequency interference is related to the wide internal bandwidth necessary for high sound quality. A radio frequency filter kit is available for some Naim equipment but sound quality will be progressively compromised as more elements of the kit are fitted.

3.5 Lightning Precautions

Your Naim hi-fi system can be damaged by lightning and should be turned off and disconnected from the mains when there is risk of lightning strike. For complete protection all mains plugs and any aerial cables should be disconnected when not in use.

3.6 Problems?

Consumer protection varies from country to country. In most territories a retailer must be prepared to take back any equipment he has sold if it cannot be made to work satisfactorily. A problem may be due to a fault in the system or its installation so it is essential to make full use of your dealer’s diagnostic skills. Please contact your local distributor, or Naim Audio directly, if any difficulties cannot be resolved.

Some Naim equipment is made in special versions for different territories and this makes it impracticable to arrange international guarantees. Please establish the local guarantee arrangements with your retailer. Contact Naim Audio directly for help and advice if necessary.

3.7 Service and Updates

It is essential that repairs and updates are only carried out by an authorised Naim retailer or at the factory by Naim itself. Many components are custom made, tested or matched and appropriate replacements are often unobtainable from other sources.

Direct contact to Naim for service or update information should be made initially through Customer Services:

Tel: +44 (0)1722 426600
Email: info@naimaudio.com

Please quote the product serial number (found on its rear panel) in all correspondence.

4. SUPERNAIT 3

The SUPERNAIT 3 is a very high performance stereo integrated amplifier that combines a preamplifier providing five line-level analogue inputs and one moving magnet phono input with a power amplifier rated at 80 Watts per channel. The SUPERNAIT 3 can be controlled by either its remote handset or by front panel mounted volume and balance knobs, and mute and input selection buttons. The SUPERNAIT 3 remote handset is described in Section 15 of this manual. A front panel 6.3mm jack socket enables the use of headphones with the SUPERNAIT 3.

A variety of power supply upgrade, alternative preamplifier and alternative or additional power amplifier options are possible for the SUPERNAIT 3. Diagrams illustrating the connection of some of these are shown in Section 6. If no power supply or alternative amplifier options are to be employed, the SUPERNAIT 3 preamp/power amp link plug, supplied in the accessory pack, must be fitted to the rear panel “preamp out” and “power amp in” sockets. The link plug is shown fitted in Diagram 5.2.

Your SUPERNAIT 3 should be installed on a dedicated equipment stand intended for the purpose. Do not stand it directly on top of another item of equipment. Care should be taken to ensure that it is level. The amplifier should be installed in its final location before connecting cables or switching on. Ensure that the volume is turned down before switching on.

4.1 Mains Power Connection

Connect the SUPERNAIT 3 to a mains power socket using either the mains cable supplied or a Naim Power-Line.

4.2 Signal Inputs

The SUPERNAIT 3 front panel input buttons select the source input signal to be routed to the integral power amplifier and the loudspeakers headphones. The six buttons are labelled cd, tuner, stream, av, phono and aux.

The cd, tuner, stream and av input buttons correspond to parallel DIN and RCA phono input sockets on the rear panel.

The phono input button corresponds to a pair of rca phono sockets compatible with moving magnet (mm) cartridges. The turntable earth lead should be connected to the ground terminal when this input is being used.

Note: The stream and av sockets carry both inputs and outputs. See Section 4.4 for more information.

The aux 2 input button corresponds to a DIN input socket on the rear panel. The aux 2 DIN socket also carries a power supply output intended to power a Naim StageLine or SuperLine phono preamplifier.

Note: For optimum sound quality DIN sockets should be used in preference to RCA phono sockets.

Note: Where an input has DIN and phono socket options only one should be connected at any one time.

Always use high quality interconnect cables to connect sources to inputs. The Naim Hi-Line will produce the best results.

4.3 Speaker Outputs

A set of stereo speaker connection sockets is provided on the rear panel. Custom Naim loudspeaker connectors are supplied to make the connection and in order to comply with current European safety regulations these should

Note: The SUPERNAIT 3 incorporates an AV Bypass switch on its rear panel. The switch should only be set to “On” if the amplifier is to be used in conjunction with an AV processor in a home theatre system. In all other installations the AV Bypass switch should be set to “Off”. Speaker and amplifier damage may occur if a signal is inadvertently connected to the SUPERNAIT 3 av input while the AV Bypass switch is “On”.

always be used. Naim speaker cable will provide the best results, however, a wide range of speaker cable types can be used without risk of damage to the amplifier.

Ensure when connecting speakers that they are “in phase”. That is, the positive and negative connection orientation at both the speaker and amplifier ends of the cable is the same for both channels.

4.4 av and stream Outputs

The SUPERNAIT 3 av and stream inputs have associated outputs that enable the selected input signal to be routed externally; to an audio recording component for example.

Note: The av and stream outputs remain active while their corresponding inputs are selected. Take care that a feedback loop is not inadvertently created by the simultaneous selection of input and output.

4.5 Headphone Output

The SUPERNAIT 3 headphone output is able to drive most headphone types. The 6.3mm (1/4”) jack socket, rather than the smaller 3.5mm jack socket, provides more reliable connection and potentially higher sound quality. Most high-quality headphones are supplied with an adaptor that enables use with either 3.5mm or 6.3mm sockets. Inserting a headphone plug will mute the SUPERNAIT 3 speaker outputs. Removing the headphone plug will restore the outputs.

4.6 AV Bypass

The SUPERNAIT 3 can be integrated within a multi-channel home theatre system, driving the front left and right channel speakers, by engaging its AV Bypass mode. AV Bypass mode enables a home theatre processor to take over volume control of signals connected to the SUPERNAIT 3 av input. It is engaged using the switch on the rear panel. The SUPERNAIT 3 volume control indicator will extinguish when AV Bypass mode is engaged and the av input is selected. The remote handset volume control will also be disabled.

SUPERNAIT 3

Note: The AV Bypass feature must be used with care. It bypasses the SUPERNAIT 3 volume control leaving any signal connected to the av input to be passed to the speakers at full volume.

Note: Inserting a headphone plug while AV Bypass mode is selected temporarily returns the SUPERNAIT 3 to normal operation. Removing the headphone plug will return the SUPERNAIT 3 to AV Bypass mode.

Note: The mute function is disabled when AV Bypass mode is engaged.

4.7 Other Signal Inputs and Outputs

The SUPERNAIT 3 incorporates DIN bi-amp (output), RCA phono sub out, DIN pre-amp out, and DIN power-amp in sockets on its rear panel. In normal use the pre-amp out and power-amp in sockets are connected by a link plug. The link plug should be removed only in the following circumstances:

- A power supply upgrade is to be used.
- An alternative preamplifier is to be used with the SUPERNAIT 3 power amplifier. See Section 4.8
- An alternative power amplifier is to be used with the SUPERNAIT 3 preamplifier.

Note: The power amp in socket carries a 24V DC power supply output intended for Naim preamplifiers that require an external power supply.

The SUPERNAIT 3 DIN bi-amp output socket provides a preamp output signal that enables a second power amplifier to be used in conjunction with the SUPERNAIT 3 power amplifier.

The RCA phono sub out sockets provide a stereo output intended for connection to an active subwoofer. The output signal is a duplicate of the preamplifier output. No low-pass filtering is applied.

Diagrams 6.1, and 6.2 illustrate some applications of the SUPERNAIT 3 preamp out, power amp in and bi-amp sockets.

4.8 Power Amp Mode Operation

If a SUPERNAIT 3 is to be used as a stereo power amp only it must be configured to operate in power amp mode:

- With the SUPERNAIT 3 switched off, remove its rear panel link plug and connect the interconnect cable from the preamp or preamp power supply to the power amp in socket
- Switch on the SUPERNAIT 3. The mute button will flash to indicate that the link plug has been removed. Press and hold the mute button until it extinguishes. The SUPERNAIT 3 is now in power amp mode. Its volume control indicator and button illumination will extinguish.

- To return the SUPERNAIT 3 to normal operation, switch it off, replace the link plug and switch it on again.

4.9 Power Supply Upgrades

The SUPERNAIT 3 preamplifier can be upgraded through the connection of an external Flatcap, Hi-Cap or Supercap power supply. The SUPERNAIT 3 and external power supply must be switched off when connections are made. Switch on the external power supply first followed by the SUPERNAIT 3 when all connections are complete.

4.10 General Connections Notes

The SUPERNAIT 3 negative input and output connections for each channel are common. The mains earth (ground) should always be connected regardless of what other equipment is used in conjunction with the amplifier. The mains earth only grounds the case and the electrostatic screen within the transformer, and is not connected to the signal negative. In order to avoid hum loops, the signal negative of the whole system should be connected to the mains earth (ground) in one place.

A signal ground connection is fitted to the SUPERNAIT 3 rear panel. This is intended to be used to connect a turntable pick-up arm signal earth only.

4.11 External Control and Interface

The SUPERNAIT 3 is fitted on its rear panel with a 3.5mm jack Remote In socket and a mini-USB interface socket.

The Remote In socket can be used for RC5 remote control of the SUPERNAIT 3 via a wired connection or a remote IR repeater.

The mini-USB socket enables firmware upgrades and diagnostic tests to be carried out. Contact your Naim retailer for more information if required.

Note: The mini-USB interface is not intended for the connection of USB memory devices.

SUPERNAIT 3

5. Controls and Connections

5.1 Front Panel Controls

Note: Icon descriptions can be found in Section 16.

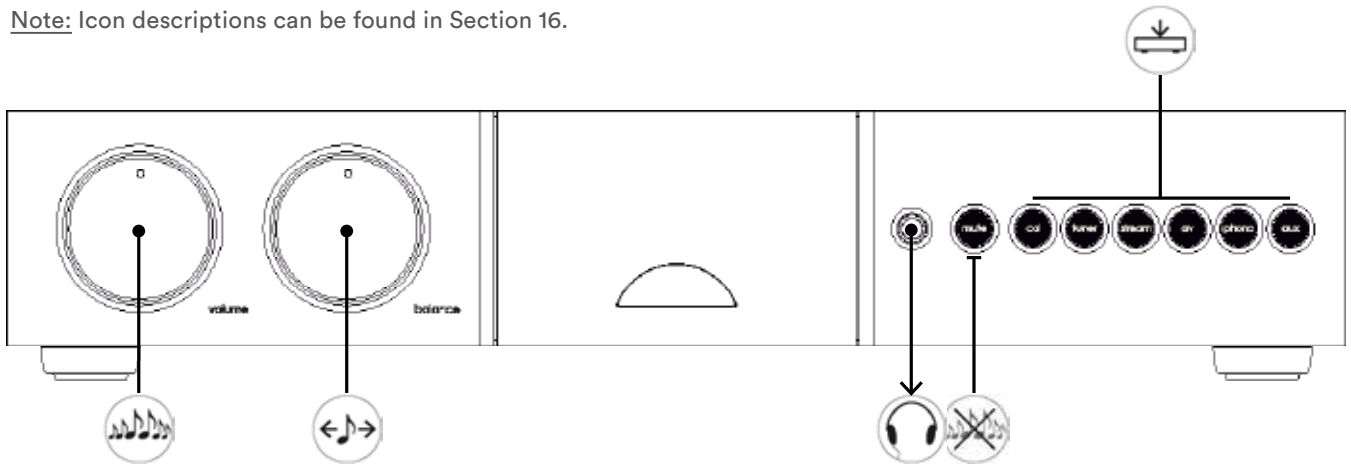

5.2 Rear Panel Connections

Note: Icon descriptions can be found in Section 16.

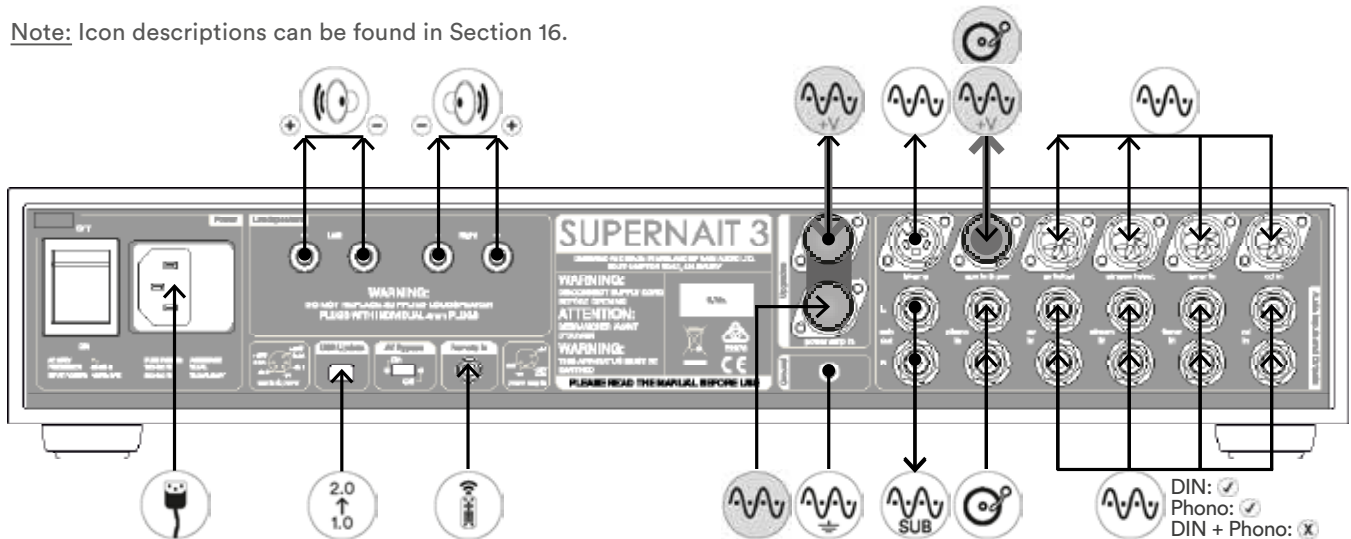

Note: The link plug should be removed only if a power supply upgrade is to be used or an alternative preamplifier is to use the SUPERNAIT 3 power amplifier section. It should remain fitted in all other circumstances.

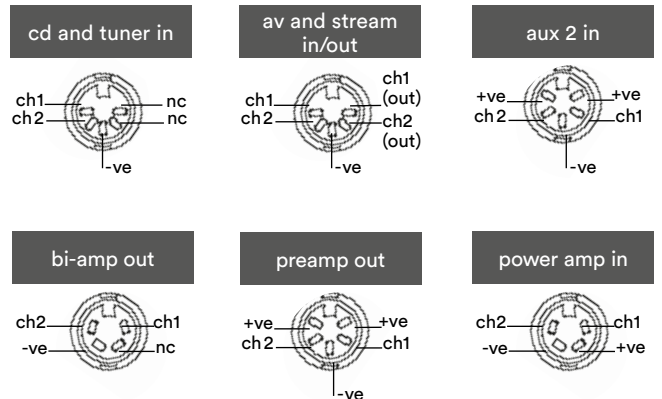

SUPERNAIT 3

6. System Upgrade Connections

The two diagrams below illustrate examples of SUPERNAIT 3 system upgrades. Other systems upgrades using external power supplies or additional power amplifiers are possible. Contact your Naim retailer or local distributor for more information. Icon descriptions can be found in Section 16.

6.1 SUPERNAIT 3 with Hi-Cap power supply and StageLine phono amplifier

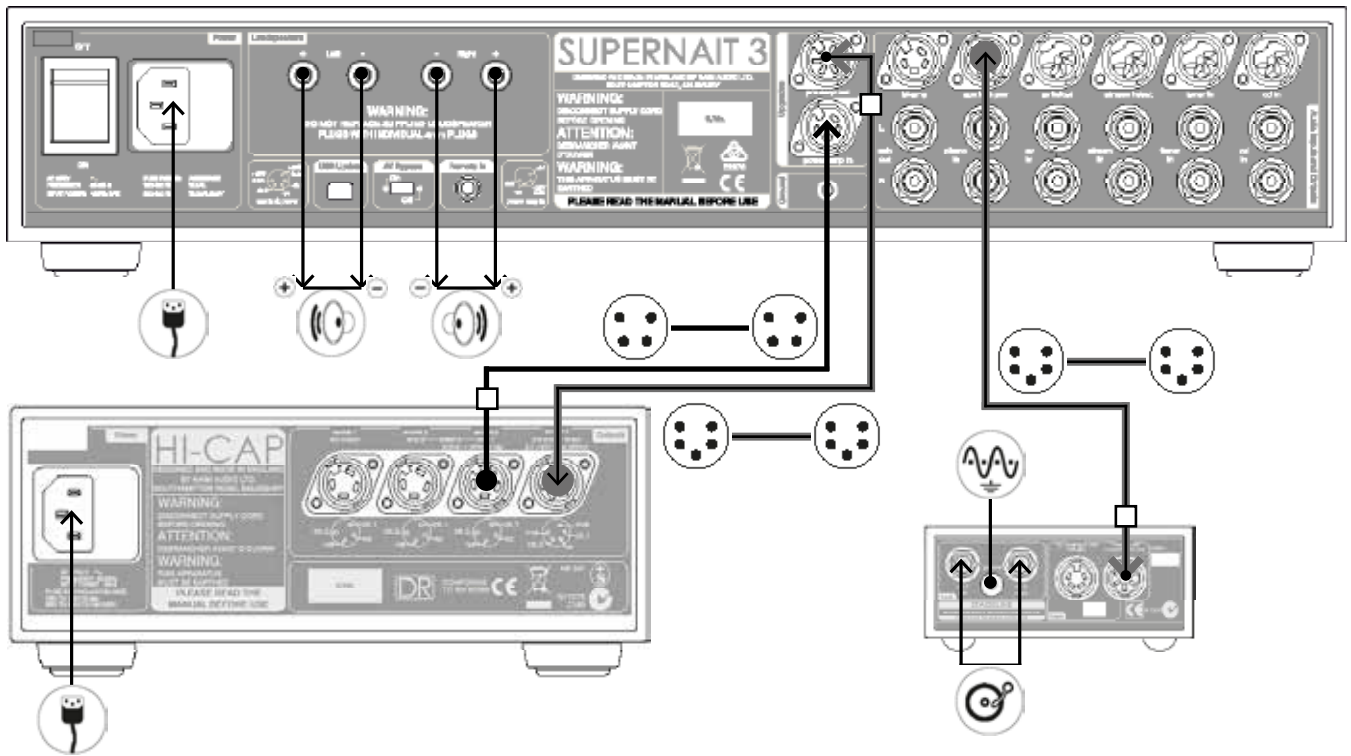

6.2 SUPERNAIT 3 with additional NAP 200 power amplifier

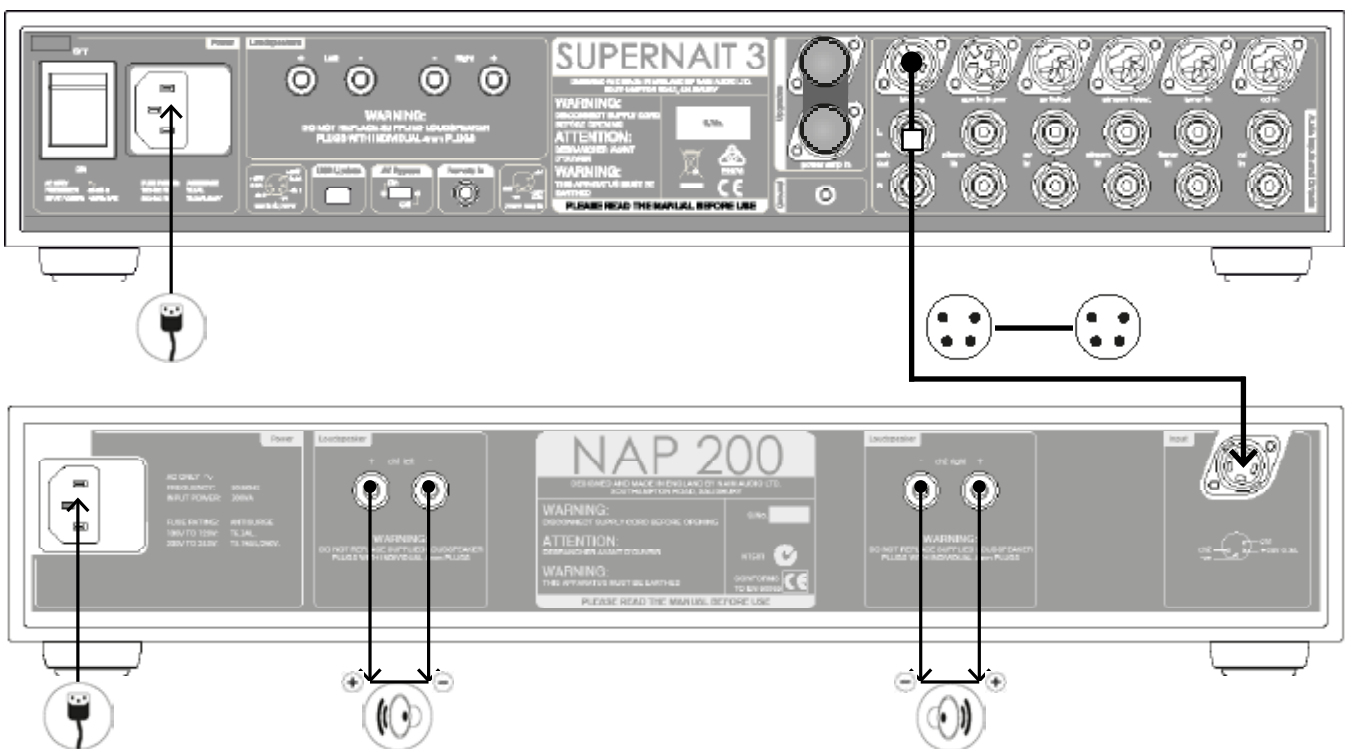

SUPERNAIT 3

7. Operation and Programmable Functions

The SUPERNAIT 3 incorporates some programmable functions and operational nuances. These are described in the following paragraphs.

7.1 Handset Volume and Balance Control

The remote handset volume and balance keys provide some alternative control characteristics. A short press and release of a key will adjust by a preset “nudge”, while pressing and holding the key will result in three seconds of slow adjustment followed by continual fast adjustment.

7.2 Mute

Mute silences the outputs and can be selected or deselected by pressing the front panel mute button or remote handset mute key.

7.3 Display

The SUPERNAIT 3 front panel button illumination can be switched off by pressing the remote handset (in preamplifier mode) disp function. Any subsequent handset or front panel operation will temporarily restore the display. A second operation of the disp function will restore the display.

7.4 Switch-on

After switch-on the SUPERNAIT 3 will remain muted for 20 seconds while control systems and circuits stabilise.

7.5 Remote Control

The NARCOM 5 remote handset supplied with the SUPERNAIT 3 duplicates all configuration and control functions. See Section 15 for more information.

7.6 Fault Conditions

The SUPERNAIT 3 will indicate fault conditions by flashing front panel button buttons. The following table lists the fault indications.

<u>Fault</u>	<u>Flashing Button</u>
Link Plug or Power Supply	mute
Excess Temperature	cd
Excess Current	tuner

8. NAIT XS 3

The NAIT XS 3 is a very high performance stereo integrated amplifier that combines a preamplifier providing five line-level analogue inputs and one moving magnet phono input with a power amplifier rated at 70 Watts per channel. The NAIT XS 3 can be controlled by either its remote handset or by a front panel mounted volume knob and mute and input selection buttons. The NAIT XS 3 remote handset is described in Section 15 of this manual. A front panel 6.3mm jack socket enables the use of headphones with the NAIT XS 3.

A variety of power supply upgrade, alternative preamplifier and alternative or additional power amplifier options are possible for the NAIT XS 3. A diagram illustrating one option is shown in Section 10. If no power supply or alternative amplifier options are to be employed, the NAIT XS 3 preamp/power amp link plug, supplied in the accessory pack, must be fitted to the rear panel "preamp out" and "power amp in" sockets. The link plug is shown fitted in Diagram 9.2.

Your NAIT XS 3 should be installed on a dedicated equipment stand intended for the purpose. Do not stand it directly on top of another item of equipment. Care should be taken to ensure that it is level. The amplifier should be installed in its final location before connecting cables or switching on. Ensure that the volume is turned down before switching on.

Note: The NAIT XS 3 incorporates an AV Bypass switch on its rear panel. The switch should only be set to "On" if the amplifier is to be used in conjunction with an AV processor in a home theatre system. In all other installations the AV Bypass switch should be set to "Off". Speaker and amplifier damage may occur if a signal is inadvertently connected to the NAIT XS 3 av input while the AV Bypass switch is "On".

8.1 Mains Power Connection

Connect the NAIT XS 3 to a mains power socket using either the mains cable supplied or a Naim Power-Line.

8.2 Signal Inputs

The NAIT XS 3 front panel input buttons select the source input signal to be routed to the integral power amplifier and the loudspeakers or headphones. The six buttons are labelled cd, tuner, stream, av, phono and aux 2.

The cd, tuner, stream and av input buttons correspond to parallel DIN and RCA phono input sockets on the rear panel.

The phono input button corresponds to a pair of rca phono sockets compatible with moving magnet (mm) cartridges. The turntable earth lead should be connected to the ground terminal when this input is being used.

Note: The stream and av sockets carry both inputs and outputs. See Section 8.4 for more information.

The aux 2 input button corresponds to a DIN input socket on the rear panel. The aux 2 DIN socket also carries a power supply output intended to power a Naim StageLine or SuperLine phono preamplifier.

Note: For optimum sound quality DIN sockets should always be used in preference to RCA phono sockets.

Note: Where an input has DIN and phono socket options only one should be connected at any one time.

Always use high quality interconnect cables to connect sources to inputs. The Naim Hi-Line will produce the best results.

8.3 Speaker Outputs

A set of stereo speaker connection sockets is provided on the rear panel. Custom Naim loudspeaker connectors are supplied to make the connection and in order to comply with current European safety regulations these should

always be used. Naim speaker cable will provide the best results, however, a wide range of speaker cable types can be used without risk of damage to the amplifier.

Ensure when connecting speakers that they are "in phase". That is, the positive and negative connection orientation at both the speaker and amplifier ends of the cable is the same for both channels.

8.4 av and stream Outputs

The NAIT XS 3 av and stream inputs have associated outputs that enable the selected input signal to be routed externally; to an audio recording component for example.

Note: The av and stream outputs remain active while their corresponding inputs are selected. Take care that a feedback loop is not inadvertently created by the simultaneous selection of input and output.

8.5 Headphone Output

The NAIT XS 3 headphone output is able to drive the majority of headphone types. The 6.3mm (1/4") jack socket, rather than the smaller 3.5mm jack socket, provides more reliable connection and potentially higher sound quality. Most high-quality headphones are supplied with an adaptor that enables use with either 3.5mm or 6.3mm jack sockets. Inserting a headphone plug will mute the NAIT XS 3 speaker outputs. Removing the headphone plug will restore the outputs.

8.6 AV Bypass

The NAIT XS 3 can be integrated within a multi-channel home theatre system, driving the front left and right channel speakers, by engaging its AV Bypass mode. AV Bypass mode enables a home theatre processor to take over volume control of signals connected to the NAIT XS 3 av input. It is engaged using the switch on the rear panel. The NAIT XS 3 volume control indicator will extinguish when AV Bypass mode is engaged and the av input is selected. The remote handset volume control will also be disabled.

Note: The AV Bypass feature must be used with care. It bypasses the NAIT XS 3 volume control leaving any signal connected to the av input to be passed to the speakers at full volume.

Note: Inserting a headphone plug while AV Bypass mode is selected temporarily returns the NAIT XS 3 to normal operation. Removing the headphone plug will return the NAIT XS 3 to AV Bypass mode.

Note: The mute function is disabled when AV Bypass mode is engaged.

8.7 Other Signal Inputs and Outputs

The NAIT XS 3 incorporates RCA phono sub out, DIN pre-amp out, and DIN power-amp in sockets on its rear panel. In normal use the pre-amp out and power-amp in sockets are connected by a link plug. The link plug should be removed only in the following circumstances:

- A power supply upgrade is to be used.
- An alternative preamplifier is to be used with the NAIT XS 3 power amplifier. See Section 8.8
- An alternative power amplifier is to be used with the NAIT XS 3 preamplifier.

Note: The power amp in socket carries a 24V DC power supply output intended for Naim preamplifiers that require an external power supply.

The RCA phono sub out sockets provide a stereo output intended for connection to an active subwoofer. The output signal is a duplicate of the preamplifier output. No low-pass filtering is applied.

8.8 Power Amp Mode Operation

If a NAIT XS 3 is to be used as a stereo power amp only it must be configured to operate in power amp mode:

- With the NAIT XS 3 switched off, remove its rear panel

link plug and connect the interconnect cable from the preamp or preamp power supply to the power amp in socket

- Switch on the NAIT XS 3. The mute button will flash to indicate that the link plug has been removed. Press and hold the mute button until it extinguishes. The NAIT XS 3 is now in power amp mode. Its volume control indicator and button illumination will extinguish.
- To return the NAIT XS 3 to normal operation, switch it off, replace the link plug and switch it on again.

8.9 Power Supply Upgrades

The NAIT XS 3 preamplifier can be upgraded through the connection of an external Flatcap, Hi-Cap or Supercap power supply. The NAIT XS 3 and external power supply must be switched off when connections are made. Switch on the external power supply first followed by the NAIT XS 3 when all connections are complete.

8.10 General Connections Notes

The NAIT XS 3 negative input and output connections for each channel are common. The mains earth (ground) should always be connected regardless of what other equipment is used in conjunction with the amplifier. The mains earth only grounds the case and the electrostatic screen within the transformer, and is not connected to the signal negative. In order to avoid hum loops, the signal negative of the whole system should be connected to the mains earth (ground) in one place.

A signal ground connection is fitted to the NAIT XS 3 rear panel. This is intended to be used to connect a turntable pick-up arm signal earth only.

8.11 External Control and Interface

The NAIT XS 3 is fitted on its rear panel with a 3.5mm jack Remote In socket and a mini-USB interface socket.

The Remote In socket can be used for RC5 remote control of the NAIT XS 3 via a wired connection or a remote IR repeater.

The mini-USB socket enables firmware upgrades and diagnostic tests to be carried out. Contact your Naim retailer for more information if required.

Note: The mini-USB interface is not intended for the connection of USB memory devices.

NAIT XS 3

9. Controls and Connections

9.1 Front Panel Controls

Note: Icon descriptions can be found on Section 16.

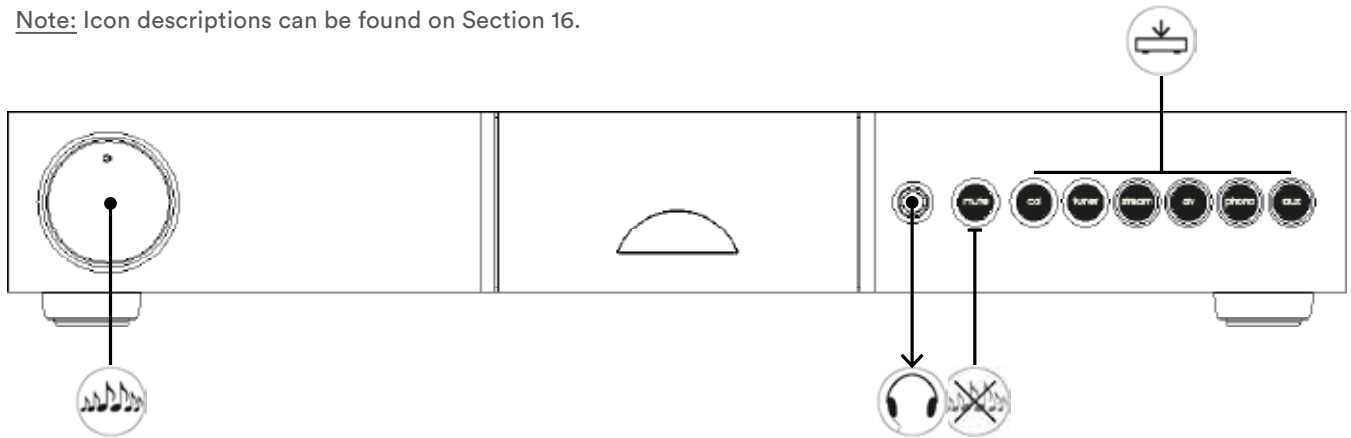

9.2 Rear Panel Connections

Note: Icon descriptions can be found on Section 16.

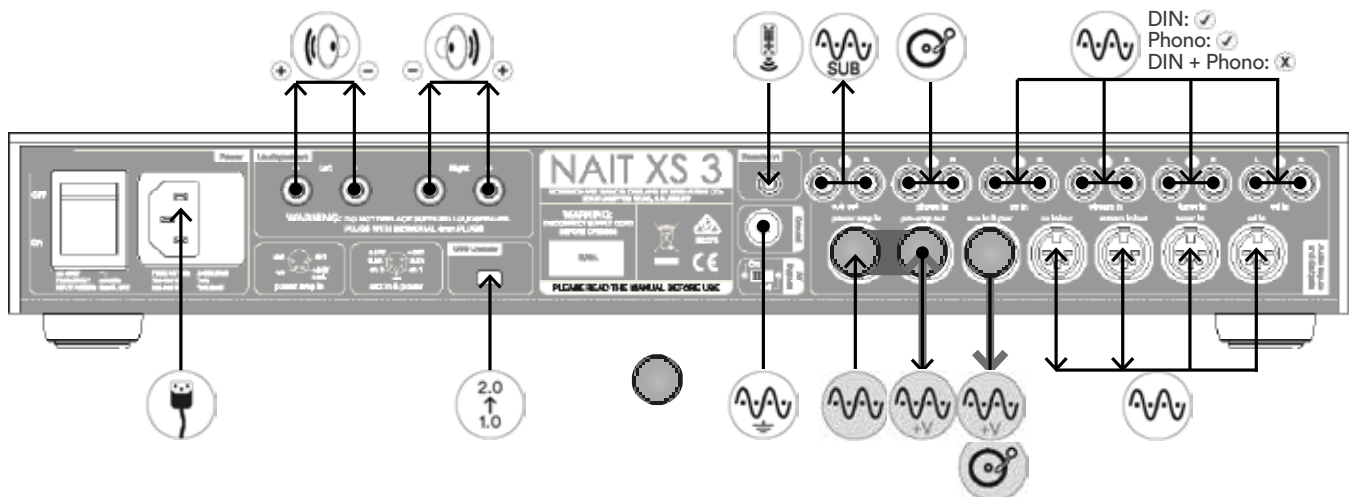

Note: The link plug should be removed only if a power supply upgrade is to be used, an alternative preamplifier is to use the NAIT XS 3 power amplifier section, or an alternative power amplifier is to use the NAIT XS 3 preamplifier section. It should remain fitted in all other circumstances.

Note: The NAIT XS 3 features various technologies to reduce microphonic effects. Some movement of the board and sockets when connecting and disconnecting cables is normal.

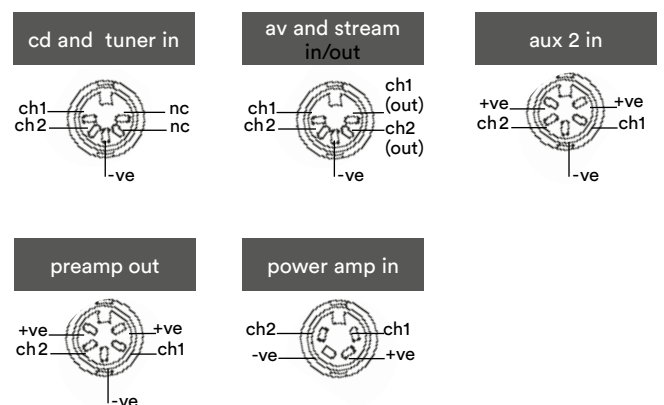

NAIT XS 3

10. System Upgrade Connections

The diagram below illustrates one example of a NAIT XS 3 system upgrade. Other system upgrades using external power supplies or additional power amplifiers are possible. Contact your Naim retailer or local distributor for more information. Icon descriptions can be found in Section 16.

10.1 NAIT XS 3 with FlatCap XS power supply and StageLine phono amplifier

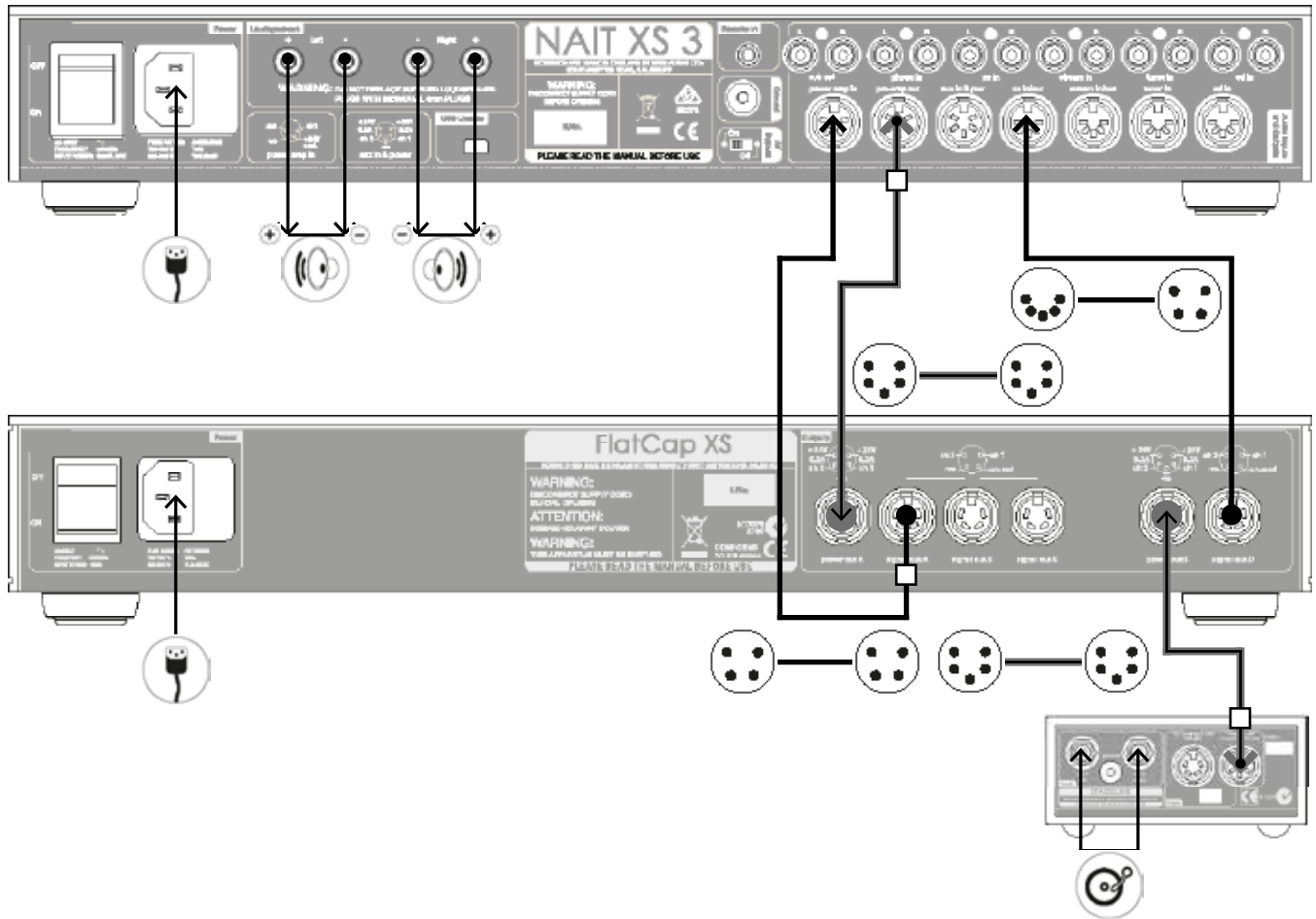

NAIT XS 3

11. Operation and Programmable Functions

The NAIT XS 3 incorporates some programmable functions and operational nuances. These are described in the following paragraphs.

11.1 Handset Volume Control

The remote handset volume keys provide some alternative control characteristics. A short press and release of a key will adjust by a preset “nudge”, while pressing and holding the key will result in three seconds of slow adjustment followed by continual fast adjustment.

Note: The NAIT XS 3 does not incorporate any facility for channel balance adjustment.

11.2 Mute

Mute silences the outputs and can be selected or deselected by pressing the front panel mute button or remote handset mute key.

11.3 Display

The NAIT XS 3 front panel button illumination can be switched off by pressing the remote handset (in preamplifier mode) disp function. Any subsequent handset or front panel operation will temporarily restore the display. A second operation of the disp function will restore the display.

11.4 Switch-on

After switch-on the NAIT XS 3 will remain muted for 20 seconds while control systems and circuits stabilise.

11.5 Remote Control

The NARCOM 5 remote handset supplied with the NAIT XS 3 duplicates all configuration and control functions. See Section 15 for more information.

11.6 Fault Conditions

The NAIT XS 3 will indicate fault conditions by flashing front panel button buttons. The following table lists the fault indications.

<u>Fault</u>	<u>Flashing Button</u>
Link Plug or Power Supply	mute
Excess Temperature	cd
Excess Current	tuner

12. NAIT 5si

The NAIT 5si is a very high performance stereo integrated amplifier that combines a preamplifier providing four line-level analogue inputs with a power amplifier rated at 60 Watts per channel. The NAIT 5si can be controlled by either its remote handset or by a front panel mounted volume knob and input selection buttons. The NAIT 5si remote handset is described in Section 15 of this manual. A front panel 6.3mm jack socket enables the use of headphones with the NAIT 5si.

Your NAIT 5si should be installed on a dedicated equipment stand intended for the purpose. Do not stand it directly on top of another item of equipment. Care should be taken to ensure that it is level. The amplifier should be installed in its final location before connecting cables or switching on. Ensure that the volume is turned down before switching on.

12.1 Mains Power Connection

Connect the NAIT 5si to a mains power socket using either the mains cable supplied or a Naim Power-Line.

12.2 Signal Inputs

The front panel input selector buttons select the source input signal to be routed to the power amplifier and the loudspeakers or headphones. The four buttons are labelled cd, tuner, hdd (hard disk drive) and av. Each input button corresponds to a pair of rear panel RCA phono input sockets. The cd and tuner inputs are additionally provided with parallel DIN sockets. These should be used in preference to the RCA phono sockets if practical. Do not connect both the DIN and RCA phono sockets of one input simultaneously.

12.3 Speaker Outputs

A stereo set of speaker connection sockets is provided on the rear panel. The sockets can accept standard 4mm plugs, but to comply with European legislation the Naim connectors supplied should be used. Naim Audio speaker cable will provide the best results; however, a wide range of speaker cable types can be used without risk of damage to the amplifier.

Ensure when connecting speakers that they are “in phase”. That is, the positive and negative connection orientation at both the speaker and amplifier ends of the cable is the same for both channels.

12.4 hdd Output

The NAIT 5si hdd input has an associated output that enable the selected input signal to be routed externally; to an audio recording component for example.

Note: The hdd output remains active regardless of which input is selected. Take care that a feedback loop is not inadvertently created by the simultaneous selection of input and output. The hdd output will be silenced when mute is engaged.

12.5 Headphone Output

The NAIT 5si headphone output is able to drive the majority of headphone types. The 6.3mm (1/4”) jack socket, rather than the smaller 3.5mm jack socket, provides more reliable connection and potentially higher sound quality. Most high-quality headphones are supplied with an adaptor that enables use with either 3.5mm or 6.3mm jack sockets. Inserting a headphone plug will mute the NAIT 5si speaker outputs. Removing the headphone plug will restore the outputs.

NAIT 5si

13. Controls and Connections

13.1 Front Panel Controls

Note: Icon descriptions can be found on Section 16.

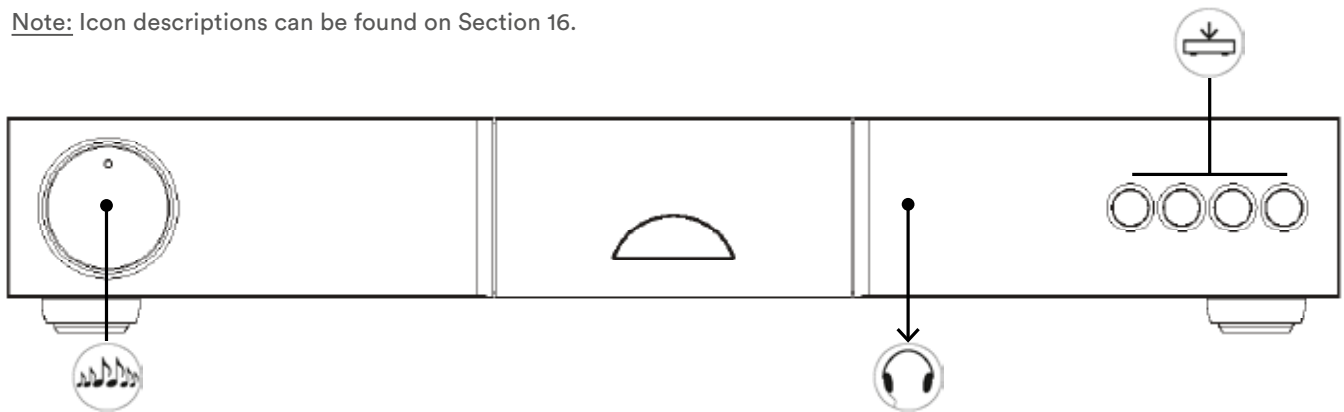

13.2 Rear Panel Connections

Note: Icon descriptions can be found on Section 16.



Note: The NAIT 5Si features various technologies to reduce microphonic effects. Some movement of the board and sockets when connecting and disconnecting cables is normal.

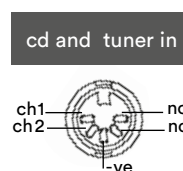

14. Operation and Programmable Functions

The NAIT 5si incorporates some programmable functions and operational nuances. These are described in the following paragraphs.

14.1 Automatic Input Switching

With Automatic Input Switching engaged the appropriate source input will be selected as soon as any handset function for that (Naim) source component is operated. For example, if the tuner input is selected and the cd play key is pressed on the handset, the NAIT 5si will automatically switch to the cd input. Automatic Input Switching can be programmed to operate on any combination of the cd, tuner, hdd and av input buttons.

To enable Automatic Input Switching, first switch the NAIT 5si into program mode by pressing and holding the handset prog key (with the handset in preamplifier mode). The front

panel hdd button will illuminate if automatic switching is already enabled. If it is not enabled it can be switched on by pressing the hdd button.

With automatic switching enabled, pressing the hdd button again will reveal the inputs selected for auto switching by their indicators illuminating for a short time. Repeated operation of the hdd button will sequentially select through each possible combination of cd, tuner, hdd and av inputs and auto switching disabled (all indicators off). When the desired inputs selected for auto switching are indicated, stop pressing the button.

NAIT 5si

Automatic Input Switching only becomes operational on exit from program mode by pressing and holding the handset prog key.

Note: The NAIT 5si will leave program mode automatically if no control commands are received for five minutes.

Note: In a few cases some further equipment configuration may be required for auto switching to operate correctly. Please contact your retailer or local distributor for advice.

14.2 AV Bypass

The NAIT 5si can be integrated within a multi-channel home theatre system, driving the front left and right channel speakers, by engaging its AV Bypass mode. AV Bypass mode enables a home theatre processor to take over volume control of signals connected to the NAIT 5si av input.

To select AV Bypass, first switch the NAIT 5si into program mode by pressing and holding the handset prog key (with the handset in preamplifier mode). The front panel av button will illuminate if AV Bypass is selected. If it is not enabled it can be switched on by pressing av button twice.

The NAIT 5si volume control indicator will extinguish when AV Bypass mode is engaged and the av input is selected. Remote handset volume control and mute function will also be disabled.

Note: The AV Bypass feature must be used with care. It bypasses the NAIT 5si volume control leaving any signal connected to the av input to be passed to the speakers at full volume.

Note: Inserting a headphone plug while AV Bypass mode is selected temporarily returns the NAIT 5si to normal operation. Removing the headphone plug will return the NAIT 5si to AV Bypass mode.

Note: The mute function is disabled when AV Bypass mode is engaged.

14.3 Handset Volume Control

The remote handset volume keys provides some alternative control characteristics. A short press and release of a key will adjust by a preset “nudge”, while pressing and holding the key will result in three seconds of slow adjustment followed by continual fast adjustment.

Note: The NAIT 5si does not incorporate any facility for channel balance adjustment.

14.4 Mute

Mute silences the outputs and can be selected or deselected by pressing the remote handset mute key.

14.5 Display

The NAIT 5si front panel button illumination can be switched off by pressing the remote handset (in preamplifier mode) disp function. Any subsequent handset or front panel operation will temporarily restore the display. A second operation of the disp function will restore the display.

14.6 Remote Control

The NARCOM 5 remote handset supplied with the NAIT 5si duplicates all configuration and control functions. See Section 15 for more information.

14.7 Defaults

To restore all NAIT 5si programmable settings to the factory defaults press and hold the remote handset disp key while the unit is in program mode. The NAIT 5si will exit from program mode following this operation.

14.8 Fault Conditions

The NAIT 5si will indicate fault conditions by flashing front panel button buttons. The following table lists the fault indications.

<u>Fault</u>	<u>Flashing Button</u>
Excess Temperature	cd
Excess Current	tuner

15. NARCOM 5 Remote Handset

The NARCOM 5 is a multifunctional remote handset designed specifically for Naim CD players, analogue tuners and preamplifiers (including integrated amplifiers). To fit batteries, remove the battery cover and insert the batteries into the body taking care with their orientation. Replace the battery cover.

15.1 Using NARCOM 5

NARCOM 5 can be configured to operate preamplifiers, tuners or CD players by pressing the appropriate System Component Key.

Note: The “rec” system component key enables record side input, mute and mono selection on appropriately equipped preamplifiers.

NARCOM 5 keys behave as described below:

- disp: Selects illumination options.
- numeric: Selects preamplifier inputs, CD tracks or tuner presets or frequencies.
- ↻: Repeats a CD or CD playlist.
- prog: Press and hold to select preamplifier program mode. Enables CD playlist programming and tuner preset management.
- vol (- / +): Adjusts volume and volume control position.
- mute: Mutes and restores volume.
- bal (- / +): Adjusts channel balance.
- mon: Enables a record device output to be heard while recording. Alternatively, selects mono mode on some products.
- ▶|||◀▶|◻: CD play, pause, previous, next and stop.
- ◀◀▶▶: CD fast reverse and forward. The keys can also select preamplifier inputs and FM radio frequencies.
- mode: Selects FM frequency, scan and preset modes.
- scan: Selects tuner scan mode. When a station is found the scan will pause. A second press will resume the scan.

15.2 NARCOM 5 keys



16. Diagram Icons



Analogue signal



Analogue signal with power supply



Subwoofer output signal



Turntable signal



Analogue signal ground connection



Left speaker output



Right speaker output



Headphones output



Input selection



Volume control



Mute control



Balance control



IEC mains supply



RC5 remote control signal



Firmware upgrade socket



Optional



180° DIN 5-pin



240° DIN 5-pin



DIN 4-pin



Signal interconnect



Signal and power interconnect



Cable direction indicator

17. Specifications

<u>Parameter</u>	<u>SUPERNAIT 3</u>	<u>NAIT XS 3</u>	<u>NAIT 5si</u>
Power Output	80W + 80W into 8Ω 135W + 135W into 4Ω	70W + 70W into 8Ω 100W + 100W into 4Ω	60W + 60W into 8Ω 95W + 95W into 4Ω
Headphones	6.3mm (1/4") Jack 16Ω to 1kΩ load impedance	6.3mm (1/4") Jack 16Ω to 1kΩ load impedance	6.3mm (1/4") Jack 16Ω to 1kΩ load impedance
Inputs	5 + mm phono (analogue line level)	5 + mm phono (analogue line level)	4 (analogue line level)
Aux Power Output	+24V (on aux 2 socket) for Naim phono stage	+24V (on aux 2 socket) for Naim phono stage	N/A
Fixed Line Outputs	av out and stream out	av out and stream out	hdd out
Variable Line Outputs	sub out, bi-amp and preamp out	sub out and preamp out	N/A
Quiescent Consumption	37VA	16VA	19VA
Mains Supply	100V, 115V or 230V, 50/60Hz	100V, 115V or 230V, 50/60Hz	100V, 115V or 230V, 50/60Hz
Dimensions (H x W x D)	87 x 432 x 314mm	70 x 432 x 301mm	70 x 432 x 301mm
Weight	13.9kg	8.4kg	6.8kg

18. Product Recycling

Products that display the crossed-out wheeled bin logo cannot be disposed of as domestic waste. These products must be disposed of at facilities capable of re-cycling them and appropriately handling any waste by-products. Contact your local authority for details of the nearest such facility. Appropriate recycling and waste disposal helps conserve resources and protects the environment from contamination.





Naim Audio Ltd. Southampton Road, Salisbury, England SP1 2LN
Call. +44 (0) 1722 426600 Email. info@naimaudio.com

naimaudio.com