

ELAC

DEBUT 3.0 SERIES

MODELS : DB53,DB63,DF53,DF63,DC53,DC63,DA43



OWNER'S MANUAL



Thank you, and Congratulations on bringing home an ELAC Debut speaker.

LEGENDARY SOUND **Begins With Passion and Innovation**

Designing the new ELAC Debut 3.0 series wasn't merely about delivering exceptional sound; it was a testament to the art of merging legendary acoustics with elevated style at accessible prices. Achieving this feat demanded a blend of creativity, vigor, and a relentless pursuit of excellence. By seamlessly marrying superior audio performance with captivating aesthetics, the ELAC Debut 3.0 series redefines what's possible in the realm of affordable audio, proving that exceptional style and legendary sound are within reach for all enthusiasts.

Enjoy!

JOURNEY TOGETHER THROUGH - THE LIFE OF SOUND

DEBUT SERIES

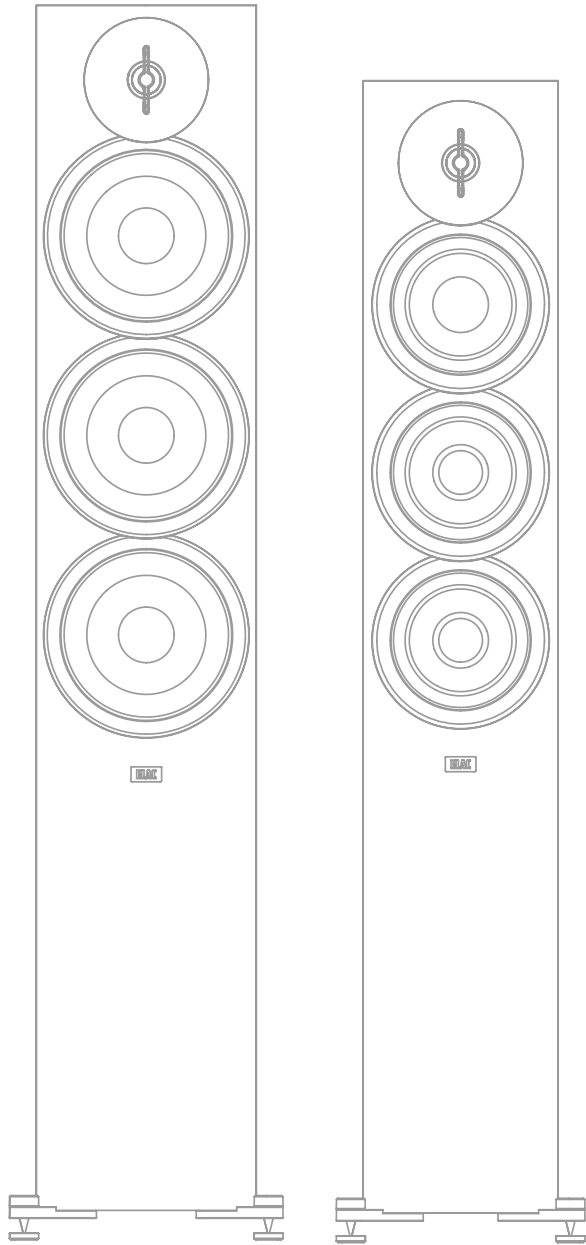

DF63

DF53

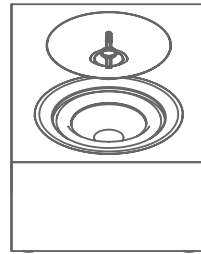

DA43

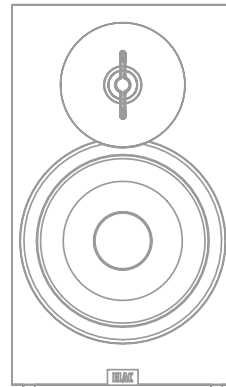

DB63

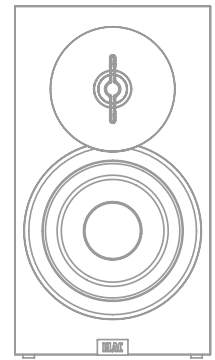

DB53

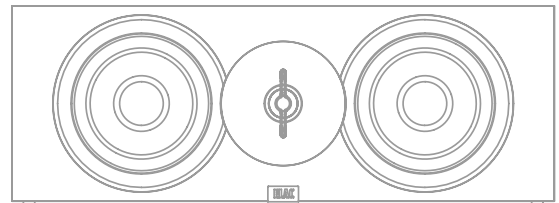

DC53

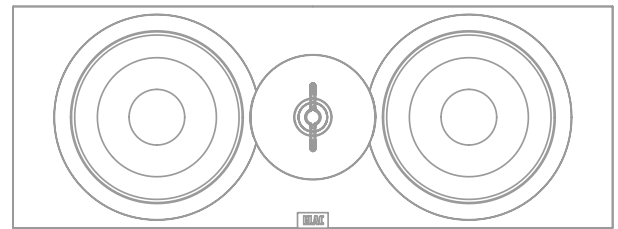

DC63

Before Use

Avoid damage to the speakers and other components:

- Unbox the speakers carefully to avoid physically damaging your speakers.
- Use appropriate gauge wires (minimum of 16 gauge wire for runs up to 25 feet).
- Make sure wire polarity is connected correctly. Most speaker cables are coded for ease of use. Make sure positive (red) connection on the amplifier terminal is connected to the positive (red) on your speakers.

Follow the same instructions for the negative side.

Strip off approximately 1/2" of the insulation from the ends of the speaker cable, twist the bare strands and insert into the binding post.

- Ensure your equipment is turned off before connecting speakers.
- Check to ensure positive and negative wires are not touching each other once they're connected to the speaker terminals.

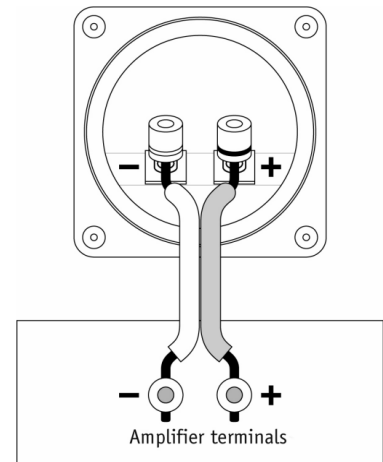

DEBUT speakers have feet and other accessories that may need to be installed prior to use. Please refer to Figure 1, 2 and 3 for installation.

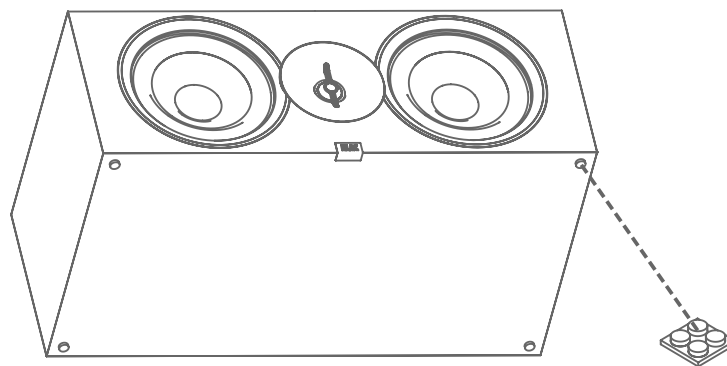

Figure 1

Before Use

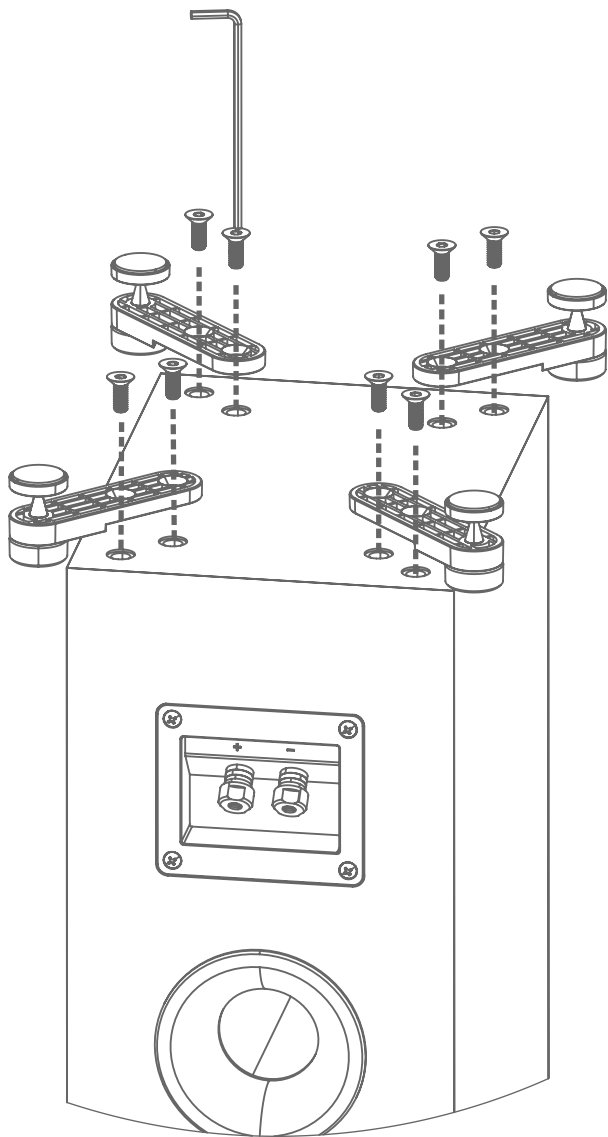

Figure 2

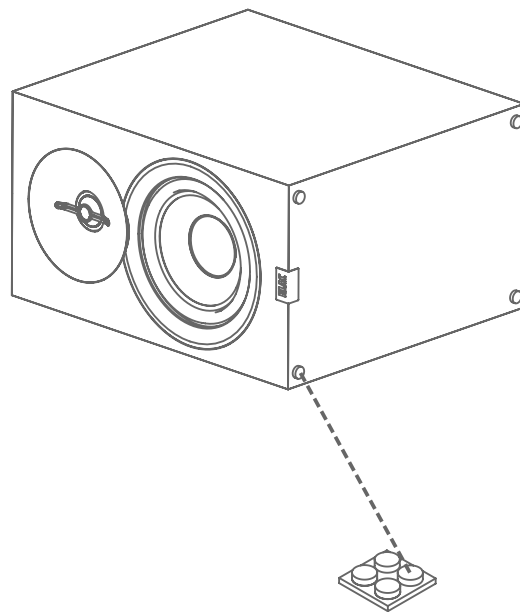
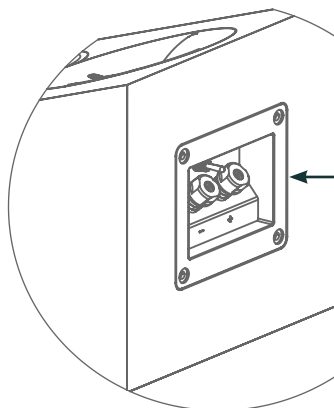
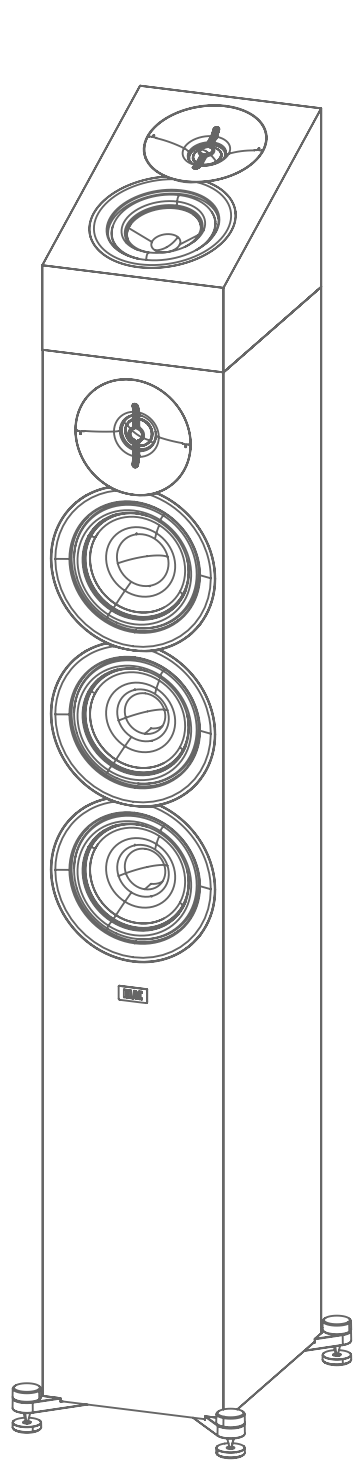

Figure 3

Atmos (DA43) Placement

Top of speaker mounting.



Set switch to Atmos for Dolby Enabled applications or Wall for Wall Mounting applications.

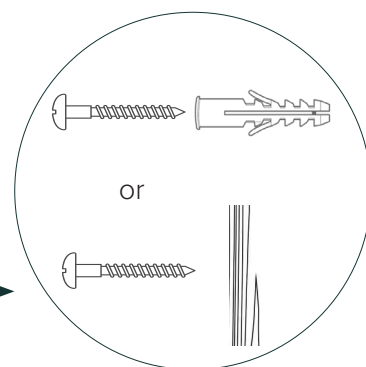
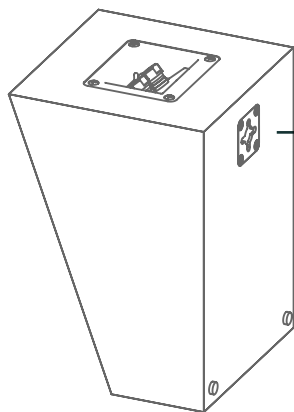

Mount in wall stud or use anchors - leave 1/4" exposed for the keyhole.



Do Not use keyhole for ceiling mounting.

Register your product

Register your product online at www.elac.com/register

- Keep up-to-date on new products and promotions.
- Your personal information will never be resold.
- This registration information is not used for warranty purposes.

Please retain your receipt for warranty claims.

Care and Cleaning

The only thing you should ever need to do to your speakers is dust them occasionally. Never apply any abrasive or solvent-based cleaner or any harsh detergent.

You can clean the grilles with the brush attachment of a vacuum cleaner.

SPEAKER PLACEMENT

Achieve maximum performance and optimal sound quality from your ELAC Debut 3.0 speakers with proper speaker placement and set-up.

While not all rooms are the same, use the following guidelines to configure the speakers for your particular room. There are no “exact” rules or boundaries in setting up your speakers but the following suggestions will help optimize your desired results. Remember the best sound set-up is what sounds best for you so don’t be afraid to experiment and make adjustments to the placement and directivity of the speakers.

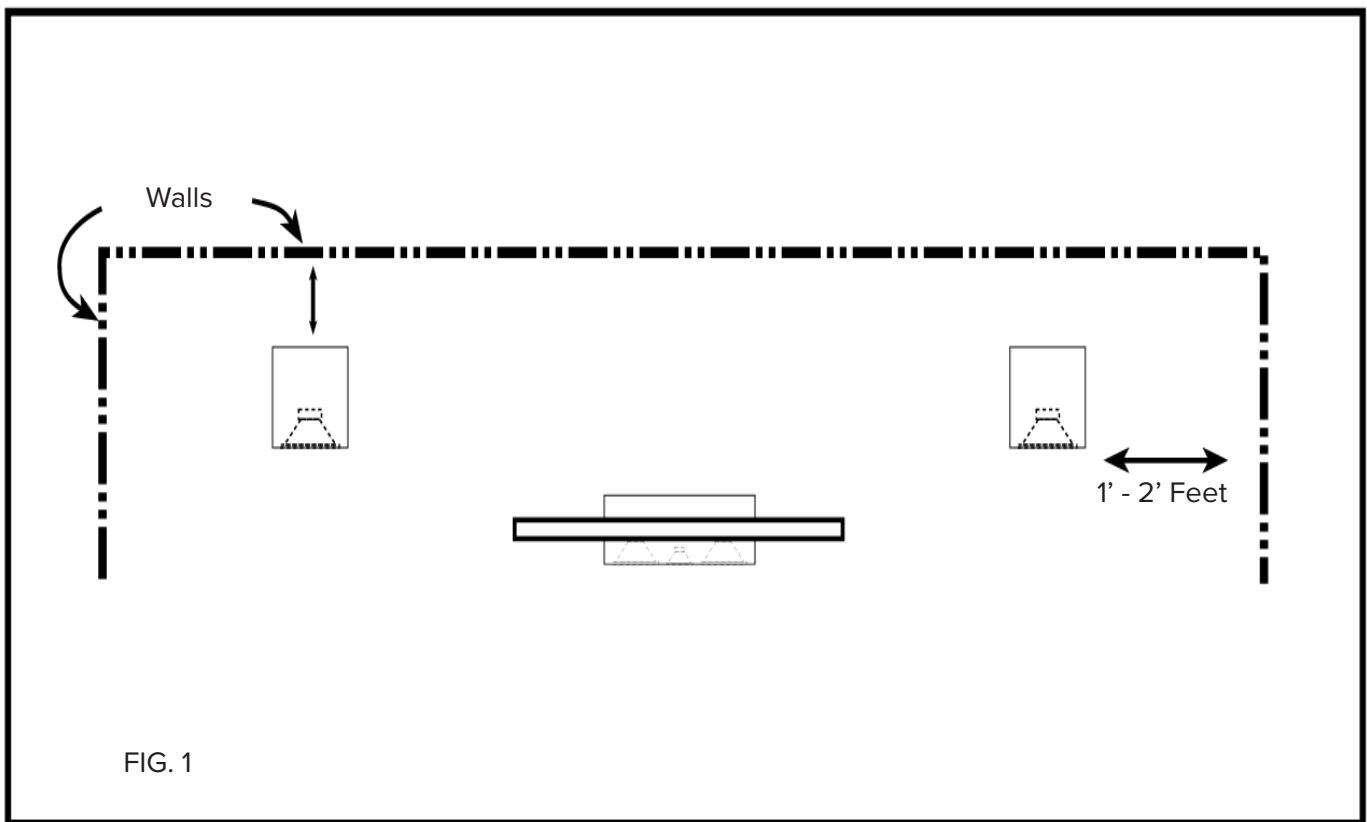

Place the speakers approximately one to two feet away (FIG. 1) from boundaries such as walls and especially corners. Close proximity to a side or rear wall will enhance bass performance (output), but being too close (particularly to a corner) may result in bass that is unnatural. If a corner location is unavoidable, try to position the loudspeaker so that the distance to the rear wall is not equal to the distance to the side wall.

STEREO SETUP

- For the best results and the most realistic stereo image and lifelike sound, place the speakers so that an equilateral triangle (fig. 2) is created between the speakers and your favorite listening position. This set up creates the optimum imaging performance.
- If you find that your B5.3/B6.3 or F5.3/F6.3 left and right speakers are too far apart, angle (toe in) them towards the listening position to gain a more focused central image.

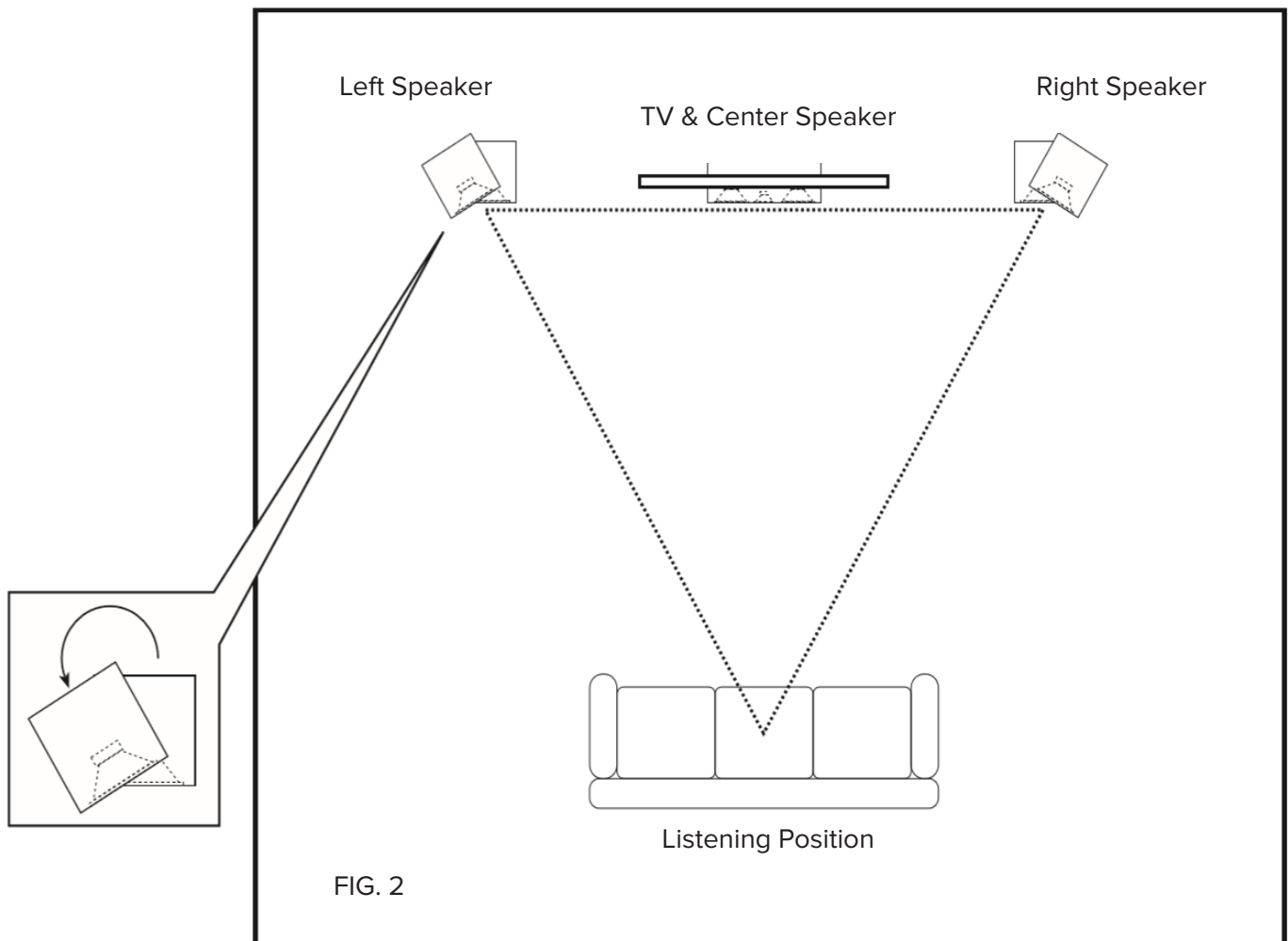

SURROUND SOUND SETUP

Whether you use the B5.3/B6.3 bookshelf or the F5.3/F6.3 floorstanding speakers for a 5.1-channel surround set-up, avoid placing the surround speakers forward of your listening position. The surround speakers should be spread apart wider than the front speakers. In addition, elevate the speakers to the same height or slightly higher as the front speakers for the most enveloping sound field. Like the front speakers, you may need to experiment with the positioning by pointing the rear surround speakers towards the listening area.

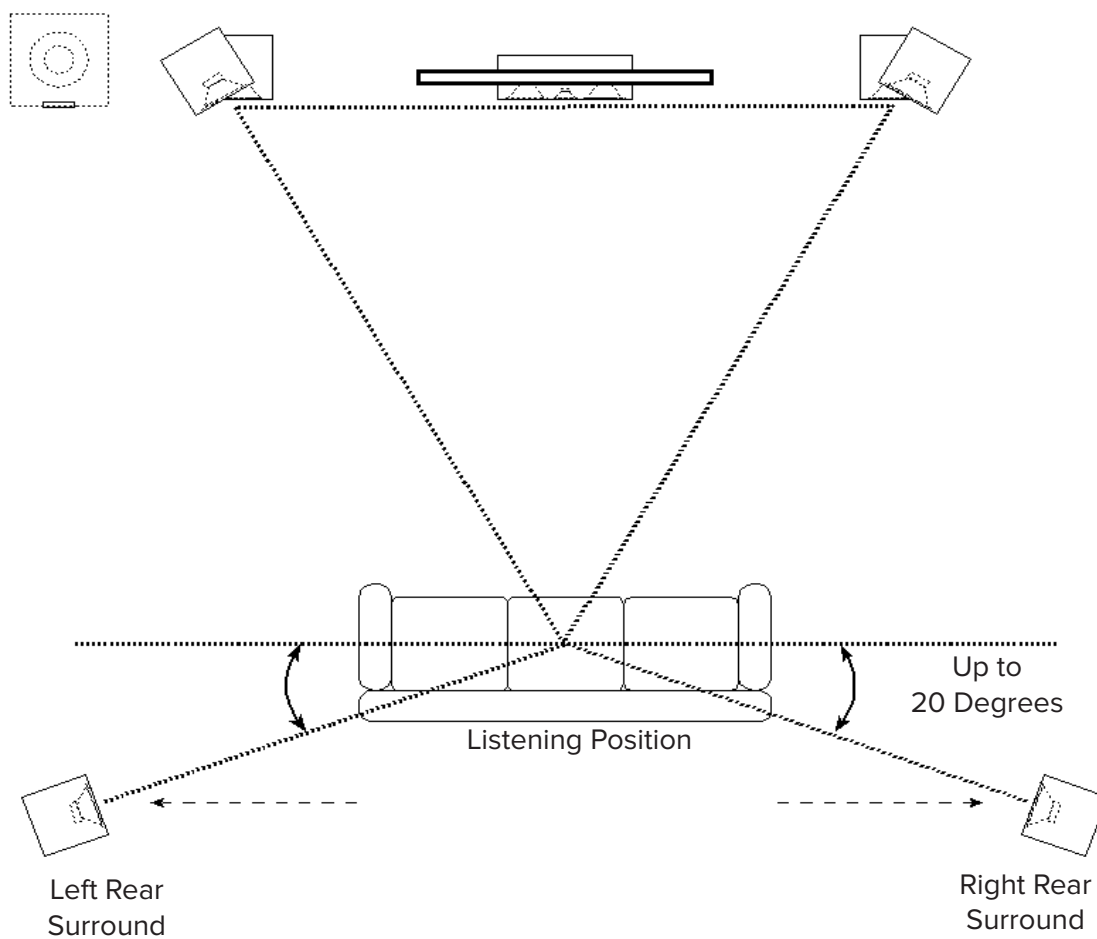

5.1-Channel Surround Set-Up

CENTER SPEAKER SETUP

The ELAC C5.3/C6.3 center channel is designed to produce dialog sounds and should be positioned above or below (fig. 3) your television. Align it with the center of the television. As much as possible, try to keep the C5.3/C6.3 close to the same level (height) as your front speakers for a more even sound stage. Keeping the same height for the center channel can be very challenging so it might be necessary to tilt the center speaker up (if too low) or down (if too high), to aim it towards the listening area.

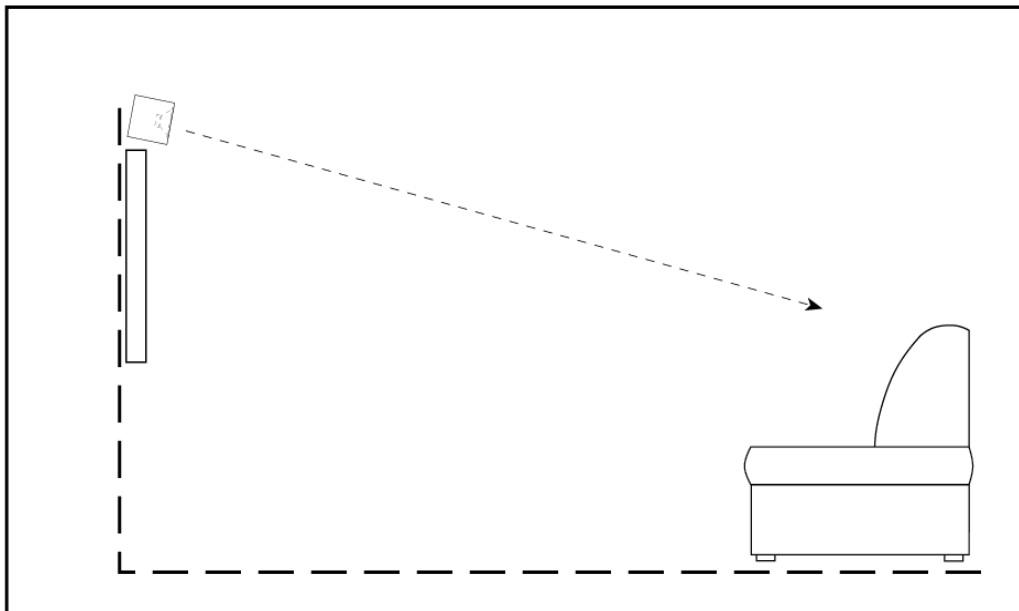
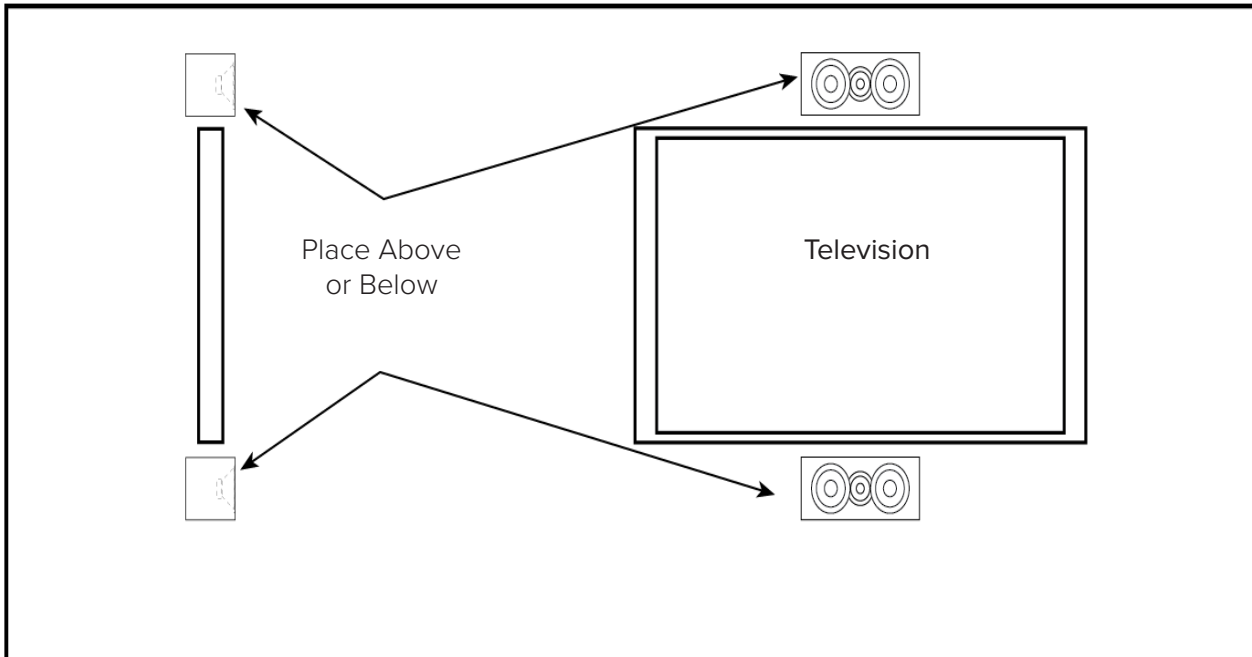

Optimal results for the center are obtained by setting the receiver/processor center channel size to small. If you have a choice, set the crossover frequency to 80Hz.

5.1.4 OVERHEAD SPEAKERS

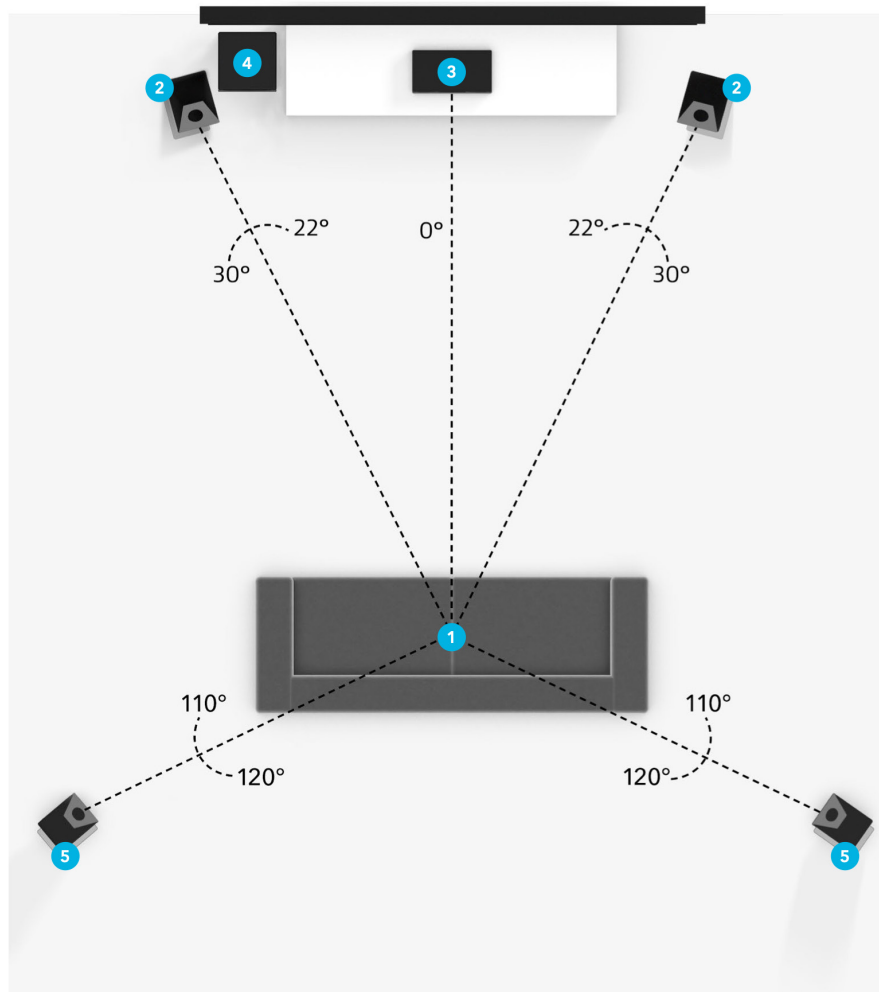

1. Seating position
2. Left & right front Dolby Atmos enabled speakers
3. Center speaker
4. Subwoofer
5. Left & right rear Dolby Atmos enabled surround speakers

5.1.4

This refers to the number of traditional surround speakers (front, center, surround, etc.)

This number refers to how many powered subwoofers you can connect to your receiver.

This refers to how many overhead or Dolby Atmos enabled speakers you can use in your Dolby Atmos capable setup.

SPECIFICATIONS

	DB53	DB63	DF53	DF63	DC53	DC63	DA43
SPEAKER TYPE	2-WAY, BASS REFLEX		3-WAY, BASS REFLEX		2-WAY, SEALED		
FREQUENCY RESPONSE	42 TO 38KHZ	42 TO 38KHZ	38 TO 38KHZ	31 TO 38KHZ	57 TO 38KHZ	50 TO 38KHZ	48 TO 38KHZ
NOMINAL IMPEDANCE	6 Ω	6 Ω	4 Ω	4 Ω	6 Ω	6 Ω	6 Ω
MINIMUM IMPEDANCE	4.8 Ω at 200 Hz	4.8 Ω at 200 Hz	4.2 Ω at 550 Hz	3.6 Ω at 500 Hz	4.8 Ω at 200 Hz	4.8 Ω at 200 Hz	5.0 Ω at 200 Hz
SENSITIVITY @2.83 V/1M	86.5 dB	87 dB	87.5 dB	87.5 dB	87.5 dB	87.5 dB	84 dB
CROSSOVER FREQUENCY	1900 HZ	2000 HZ	500 HZ, 2100 HZ	550 HZ, 2000 HZ	1900 HZ	2000 HZ	2400 HZ
RECOMMENDED AMPLIFIER POWER	20 - 120 W	20 - 140 W	30 - 150 W	30 - 180 W	30 - 120 W	30 - 140 W	20 - 80 W
NOMINAL/PEAK POWER HANDLING	120 W	120 W	140 W	140 W	120 W	120 W	80 W
TWEETER	1 - INCH ALUMINUM DOME						
MIDRANGE (ARAMID-FIBER)	-	-	2 x 5 ¼ "	2 x 6 ½ "	-	-	-
WOOFER (ARAMID-FIBER)	5 ¼ "	6 ½ "	5 ¼ "	6 ½ "	2 x 5 ¼ "	2 x 6 ½ "	4.0 "
CABINET	CARB2 RATED 16MM MDF						
CABINET FINISH	BLACK ASH VINYL, SATIN BLACK VINYL FRONT						
PORT	DUAL FLARED				SEALED		
BINDING POST	5-WAY METAL						
WIDTH (IN / MM)	6.8/172	7.7/195	6.8/172	7.7/195	19.0/482	21.0/533	6.8/172
HEIGHT (IN / MM)	12.2/311	13.3/339	40.6/1030	43.1/1094	6.8/172	7.7/195	6.7/170
DEPTH (IN / MM)	10.5/267	11.7/298	9.7/246	10.6/268	9.2/234	11.7/298	9.7/246
Net Weight (lbs / KG)	13.34/6.05	17.3/7.85	34.6/15.7	38.8/17.6	19.2/8.7	23.6/10.7	7.3/3.3

SAFETY INSTRUCTIONS

1. General information

- Please read and follow these safety instructions.
- Keep them safe for future reference.
- Observe all warnings on the speaker and in the manual. Please check the speaker for damage before use. The speaker must be in perfect working condition. Damaged parts may lead to personal injury.

2. Use only as directed

- Connect the speaker(s) according to the instructions in the manual.
- Many ELAC speakers are equipped with spikes and/or anti-slip feet. They are explicitly provided for leveling the speaker. For leveling on an uneven floor, unscrew the spikes or anti-slip feet by 2-3 turns of thread. The speaker should always be in perfect vertical alignment: the stability of the speaker must not be compromised by using spikes or anti-slip feet as the speaker may tip-over.

3. Location

- Install the speakers on a level surface only.
- When choosing the location of these speakers do not place them in locations that are:
 - In direct sunlight
 - Very humid
 - Prone to vibrations
 - Exceptionally hot or cold
 - Near CRT Televisions (the speakers are not magnetically shielded and may cause color issues with a CRT based TV).sa
 - Close to magnetic cards (Since the speakers are not magnetically shielded placing magnetic cards such as credit cards or commuter cards may cause them to fail).

4. Overload

Please ensure the product is perfectly stable to avoid injury from tip-over. Please note, that stability can be increased by using spikes on carpeted surfaces. However, the mounting of spikes must be carried out carefully due to their very sharp ends which may cause injuries. The stability on slippery floors can be increased by using Velcro fastening tape or double-sided adhesive tape. Do not install the speaker near any heat sources such as radiators, heating valves, stoves, or other apparatus (including amplifiers) that produce heat, or in areas where there is a risk of explosion.

- Do not block any ventilation openings. Install in accordance with the manufacturer's instructions.
- Do not install the speaker in a closed rack or in a closed cupboard.
- Do not put burning candles on or near the speaker.
- Do not install the speaker near transformers because electromagnetic stray fields can cause hum noise on woofers.
- In combination with certain materials / lacquers / material surfaces, anti-slip feet or spike washers may cause colored imprints on the surfaces.

5. Overload

Extreme overload of the device due to very high volume may cause individual components to blow. Because of the possible danger, you should never leave loudspeakers under extreme overload conditions unattended.

6. Service

DANGER! Do not open the cabinet because the components and conductors may carry dangerous levels of electricity! Servicing to be carried out by qualified service personnel only.

Servicing is required when the loudspeaker has been damaged in any way, such as damage to the power supply cord or the plug, or when liquid has been spilled or objects have fallen into the loudspeaker, the speaker has been exposed to rain or moisture, does not operate normally, or has been dropped. To reduce the risk of electric shock, do not open the loudspeaker. Servicing to be carried out by qualified service personnel only .

7. Fuse links

Various faults in subwoofers or active speakers may cause the fuse to blow. If the fuse blows, only replace it with the correct fuse type and rating as shown on the rear of the loudspeaker on the fuse holder. A second fuse is included with the device (in the fuse holder beneath the mains socket).

8. Cleaning

NOTE: Clean only with soft, smooth cloth or with dust brush. Do not use scouring agents, alcohol, benzene, furniture polish or other agents for cleaning! Modern furniture is often coated with multiple varnishes and plastics which can be treated with chemical agents. Some of these agents contain substances which degrade or soften the rubber feet. Therefore, we advise you to place an anti-slip mat underneath the loudspeaker.

9. Volume

CAUTION! Continuous high volume may cause severe damage to your hearing. Please listen responsibly.

10. Disposal

The packaging is made from recyclable materials. Dispose of this in an environmentally friendly manner. At end of product life do not dispose of the speaker(s) with standard household waste. The speaker must be recycled in accordance with local legislation. Ask your local government for further information on recycling as the device contains valuable raw materials. Disable the speaker before disposal.

11. Power

This subwoofer is only intended to be connected to voltages that are listed on the rear panel of the cabinet. Connection to any other voltage may cause irreversible damage to the subwoofer and will void the warranty. Use of plug adapters is not recommended because they may allow connection to voltages other than those printed on the back of this subwoofer.

WARRANTY

ELAC Americas Inc.

North America Limited Liability Warranty

ELAC Americas Inc. warrants to the original purchaser that this product be free from defects and or workmanship for a period of 3 (Three) years from the original date of purchase. During this time period, repair or replacement of parts will be free of charge to the original owner (See below limitations). Shipping to and return from the repair center will be the responsibility of the original purchaser.

Limitations

- Warranty begins on the date of original purchase from an authorized ELAC Americas Inc. dealer.
- Product is warranted only if used in home applications within the max power rating specified in this manual. Commercial use of this product is not warranted.
- Product that has been modified or altered in anyway will not be warranted.
- Product that has been abused or subjected to faulty equipment will not be warranted.
- Products with defaced or removed serial numbers will not be warranted.

If service is required

In the event that service is required, please contact ELAC America at 888-541-0996 or at customerservice@elac.us to arrange for service or replacement. You will be responsible to provide proof of purchase (Copy or original sales receipt). Shipping to and from our repair center will be the responsibility of the original purchaser.

Warranty Outside of North America

This warranty applies to products purchased in the United States and Canada. For warranty claims outside of North America please contact the local dealer/distributor in the country of purchase.

DEBUT
3.0

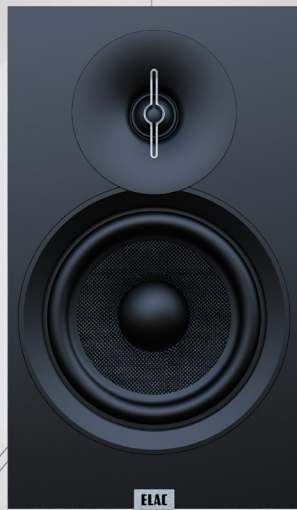

LEGENDARY SOUND
ELEVATED STYLE
WHERE VISION MEETS VOICE

ELAC.COM

ELAC The life of sound.

ELAC AMERICAS INC.
1938 N. BATAVIA St. SUITE K
ORANGE, CA 92865

ELAC ELECTROACUSTIC GMBH
FRAUNHOFERSTRASSE 16
D-24118 KIEL, GERMANY